

Damping and incremental energy in thyristor switching circuits

Rajesh Rajaraman

Ian Dobson

Electrical and Computer Engineering Department
 University of Wisconsin, Madison, WI, 53706 USA
 e-mail: dobson@engr.wisc.edu

Abstract : Thyristor controlled reactors provide controllable inductances in utility power lines and are increasingly used for static var control and flexible AC transmission. The size of a perturbation from a nominal periodic steady state can be measured by its incremental energy. This paper shows that incremental energy of a small perturbation increases when a thyristor switches on and decreases when a thyristor switches off. This observation aids in understanding how perturbations are damped by thyristor switchings and highlights some problems with representing the small signal dynamics of thyristor controlled reactors with impedances.

1. Introduction

A thyristor controlled reactor is a pair of back-to-back thyristors in series with a reactor (inductor) and provides the effect of a controllable inductance in utility power lines. The thyristors switch to include the reactor in the circuit in portions of the AC supply cycle to change the effective inductance at the fundamental. The thyristor controlled reactor is often used in parallel with a fixed capacitor to provide the effect of a variable capacitance. This variable capacitance finds application in static var control [12] and in the emerging technology of flexible AC transmission [1,10]. Thyristor controlled reactor circuits are a good choice for studying switching circuit dynamics since they are useful, simple in form and exhibit interesting nonlinear behaviour.

Sanders [14] uses incremental energy methods to show that circuits with incrementally passive diode models are stable. Here we use incremental energy to study how thyristor switchings increase or decrease the energy of perturbations to a nominal periodic steady state.

2. Incremental energy changes at switchings.

This section describes and quantifies to leading order changes in incremental energy of a perturbation at thyristor switchings. Consider a circuit of inductors, capacitors, sources and a single thyristor controlled reactor. The circuit sources are assumed to be smooth periodic functions of time with period T . The lack of circuit resistance allows the damping due to switchings to be studied by itself. It is convenient in the sequel to focus on only one of the thyristors, although both are used in typical AC cycle. The thyristor is modeled as an ideal diode with a gate. The thyristor turns on when a firing pulse is applied at the gate and its voltage $v(t)$ is positive, conducts current $i(t)$ only in the forward direction, and turns off when the current through the thyristor becomes zero. The thyristor current $i(t)$ and voltage $v(t)$ are shown in Fig. 1. Throughout the paper, a thyristor firing at, say, s_{on} is assumed to occur with $v(s_{\text{on}}-) > 0$ so that there is no misfire [13]

and a thyristor switch off at, say, s_{off} is assumed to occur with $\frac{di}{dt}(s_{\text{off}}-) < 0$ so that there is no switching time bifurcation [6,13,4].

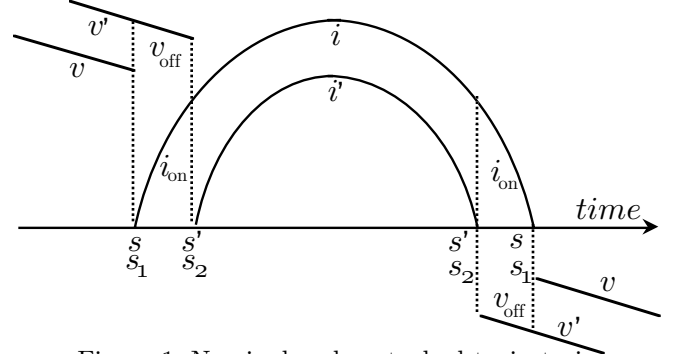

Figure 1. Nominal and perturbed trajectories.

For a given nominal trajectory of the circuit, let $i_k(t)$ and $v_k(t)$ be the current in and voltage across circuit component number k as a function of time t . Let $i'_k(t)$ and $v'_k(t)$ be the k th component current and voltages associated with a trajectory which is perturbed from the nominal trajectory. Define the incremental current $\delta i_k = i'_k(t) - i_k(t)$ and incremental voltage $\delta v_k = v'_k(t) - v_k(t)$. Then, despite the circuit switchings, Tellegen's theorem applies at every instant so that

$$0 = \delta i \delta v + \sum_{\text{inductors}} \delta i_k \delta v_k + \sum_{\text{capacitors}} \delta i_k \delta v_k + \sum_{\text{sources}} \delta i_k \delta v_k \quad (2.1)$$

The summation over sources vanishes because $\delta v_k = 0$ for voltage sources and $\delta i_k = 0$ for current sources. Define the incremental energy of the perturbation by

$$E = \frac{1}{2} \sum_{\text{inductors}} L_k (\delta i_k)^2 + \frac{1}{2} \sum_{\text{capacitors}} C_k (\delta v_k)^2 \quad (2.2)$$

E is smooth between switchings. For any time between switchings, differentiate (2.2) and use (2.1) to obtain

$$\begin{aligned} \frac{dE}{dt} &= \sum_{\text{inductors}} \delta i_k \delta v_k + \sum_{\text{capacitors}} \delta i_k \delta v_k = -\delta i \delta v \\ &= -(i'(t) - i(t))(v'(t) - v(t)) = \\ &\begin{cases} 0 & ; \text{thyristor on for both trajectories} \\ 0 & ; \text{thyristor off for both trajectories} \\ i(t)v'(t) & ; \text{thyristor on for nominal, off for dashed} \\ i'(t)v(t) & ; \text{thyristor on for dashed, off for nominal} \end{cases} \end{aligned}$$

When the thyristor is on for one trajectory and off for the other trajectory, write i^{on} for the on thyristor current and v^{off} for the off thyristor voltage. Then

$$\frac{dE}{dt} = \begin{cases} 0 & ; \text{thyristor same for both trajectories} \\ i^{\text{on}}(t)v^{\text{off}}(t) & ; \text{thyristor on for one trajectory} \\ & \text{and off for the other.} \end{cases} \quad (2.3)$$

Suppose that the nominal trajectory turns on or off at time s and that the perturbed trajectory switches in the same way but at time s' . According to (2.3), the incremental energy only changes in the time interval (s, s') when the thyristor is on for one trajectory and off for the other trajectory. See the switch on and switch off in Fig. 1; other cases arise when the dashed and undashed variables of Fig. 1 are exchanged at either switching. We want to evaluate the total change in incremental energy over (s, s') :

$$\Delta E = E(\max\{s, s'\}) - E(\min\{s, s'\})$$

If s and s' are switch ons, define $s_1 = \min\{s, s'\}$ and $s_2 = \max\{s, s'\}$. If s and s' are switch offs, define $s_1 = \max\{s, s'\}$ and $s_2 = \min\{s, s'\}$. Then

$$\Delta E = \pm (E(s_2) - E(s_1)) ; \quad \begin{cases} + & \text{for switch on,} \\ - & \text{for switch off.} \end{cases}$$

and
$$\Delta E = \pm \int_{s_1}^{s_2} i^{\text{on}}(t) v^{\text{off}}(t) dt \quad (2.4)$$

For switch on, $s_1 \leq s_2$, $v^{\text{off}}(t) > 0$, $i^{\text{on}}(t) \geq 0$ and hence $\Delta E \geq 0$. For switch off, $s_1 \geq s_2$, $v^{\text{off}}(t) < 0$, $i^{\text{on}}(t) \geq 0$ and hence $\Delta E \leq 0$. Thus incremental energy increases or is unchanged at a switch on and decreases or is unchanged at a switch off. The incremental energy is unchanged if the switching time of the perturbed trajectory is the same as the switching time of the nominal trajectory ($s_1 = s_2$).

In the switch on of Fig. 1, the voltage across the entire thyristor controlled reactor is continuous and $v(s_{1-}) = L_r \frac{di^{\text{on}}}{dt}(s_{1+})$ and $v^{\text{off}}(s_{1+}) = v'(s_{1-}) = v(s_{1-}) + O(\delta x)$ where $\delta x = x'(t) - x(t)$ is the difference of the states of the perturbed and nominal trajectories and L_r is the reactor inductance. Hence, and similarly for the other cases, $v^{\text{off}}(s_{1\pm}) = L_r \frac{di^{\text{on}}}{dt}(s_{1\pm}) + O(\delta x)$. Since also $i^{\text{on}}(s_1) = 0$, we have for $t \in (s_1, s_2)$,

$$v^{\text{off}}(t) = L_r \frac{di^{\text{on}}}{dt}(t) + O((t - s_1)) + O(\delta x) \quad (2.5)$$

$$i^{\text{on}}(t) = \left(\frac{di^{\text{on}}}{dt}(s_{1\pm})\right)(t - s_1) + O((t - s_1)^2) \quad (2.6)$$

and, writing $\delta s = s_1 - s_2$ and noting that $i^{\text{on}}(t) = O(\delta s)$ for $t \in (s_1, s_2)$,

$$\begin{aligned} \Delta E &= \pm \int_{s_1}^{s_2} i^{\text{on}}(t) L_r \frac{di^{\text{on}}}{dt}(t) dt + O(\delta s^3) + O(\delta x \delta s^2) \\ &= \pm \frac{1}{2} L_r (i^{\text{on}}(s_2))^2 + O(\delta s^3) + O(\delta x \delta s^2) \quad (2.7) \end{aligned}$$

$$= \pm \frac{1}{2} L_r (\delta i(s_2))^2 + O(\delta s^3) + O(\delta x \delta s^2) \quad (2.8)$$

The leading order term of (2.8) shows, for a switch on, an incremental energy increase by the incremental reactor energy at the second switch on and shows, for a switch off, an incremental energy decrease by the incremental reactor energy at the first switch off.

From (2.6), $i^{\text{on}}(s_2) = \left(\frac{di^{\text{on}}}{dt}(s_{1\pm})\right) \delta s + O(\delta s^2)$. Either $\frac{di^{\text{on}}}{dt}(s_{1\pm}) = \frac{di}{dt}(s_{\pm})$ (see Fig. 1) or $\frac{di^{\text{on}}}{dt}(s_{1\pm}) = \frac{di'}{dt}(s'_{\pm}) = \frac{di'}{dt}(s_{\pm}) + O(\delta s) = \frac{di}{dt}(s_{\pm}) + O(\delta s) + O(\delta x)$ (see Fig. 1 with dashed and undashed variables interchanged). Hence formulas depending only on the nominal trajectory are:

$$\Delta E = \pm \frac{1}{2} L_r \left(\frac{di}{dt}(s_{\pm})\right)^2 \delta s^2 + O(\delta s^3) + O(\delta x \delta s^2) \quad (2.9)$$

$$= \pm \frac{1}{2 L_r} (v(s_{\mp}))^2 \delta s^2 + O(\delta s^3) + O(\delta x \delta s^2) \quad (2.10)$$

3. Energy in the Linearized System

Thyristor circuits can be linearized about the nominal trajectory (see [11,3,4]). This section shows how the changes in incremental energy at switchings may be derived from the linearized system equations.

The circuit equations are presented first. Under mild assumptions, the appendix shows how to choose 'nice' coordinates [4] for the circuit state $x(t) \in \mathbb{R}^n$. The thyristor current is given by the first of the nice coordinates so that

$$i(t) = \sqrt{(2/L_r)} c x(t) \quad (3.1)$$

where $c = (100 \dots 0)$. When the thyristor is on, the system equations are

$$\dot{x} = Ax + Bu \quad (3.2)$$

where A is an $n \times n$ matrix and the vector u represents the circuit sources. When the thyristor is off, the circuit state $y \in \mathbb{R}^{n-1}$ is given by the last $n-1$ coordinates of x so that $y = Px$ where P is the last $n-1$ rows of an $n \times n$ identity matrix. Define $Q = P^t$. When the thyristor is off, the system equations are

$$\dot{y} = PAQy + PBu \quad (3.3)$$

Note that $cQ = 0$, $PQ = I$, and $QP + c^t c = I$.

The states at a switch off time s_{off} are related by

$$y(s_{\text{off}+}) = Px(s_{\text{off}-}) \quad (3.4)$$

and the states at a switch on time s_{on} are related by

$$x(s_{\text{on}+}) = Qy(s_{\text{on}-}) \quad (3.5)$$

We now linearize the system equations (3.2-3.5) about the nominal trajectory. Linearizing (3.2) and (3.3) gives

$$\delta \dot{x} = A \delta x \quad (3.6)$$

$$\delta \dot{y} = PAQ \delta y \quad (3.7)$$

Linearizing (3.4) (also see [11,3,4]) yields

$$\begin{aligned} \delta y(s_{\text{off}+}) &= P \delta x(s_{\text{off}-}) + (P \dot{x}(s_{\text{off}-}) - \dot{y}(s_{\text{off}+})) \delta s_{\text{off}} \\ &= P \delta x(s_{\text{off}-}) \quad (3.8) \end{aligned}$$

since (3.2), (3.4) and (3.3) imply that

$$P \dot{x}(s_{\text{off}-}) = PAQy(s_{\text{off}+}) + PBu(s_{\text{off}}) = \dot{y}(s_{\text{off}+}).$$

Linearizing (3.5) (also see [11]) yields

$$\begin{aligned} \delta x(s_{\text{on}+}) &= Q \delta y(s_{\text{on}-}) + (Q \dot{y}(s_{\text{on}-}) - \dot{x}(s_{\text{on}+})) \delta s_{\text{on}} \\ &= Q \delta y(s_{\text{on}-}) - c^t c \dot{x}(s_{\text{on}+}) \delta s_{\text{on}} \quad (3.9) \end{aligned}$$

since (3.3), (3.5), (3.2) and $QP + c^t c = I$ imply that

$$Q \dot{y}(s_{\text{on}-}) = QP \dot{x}(s_{\text{on}+}) = (I - c^t c) \dot{x}(s_{\text{on}+})$$

The incremental energy of a small perturbation $\delta x(t)$ from the nominal trajectory in the circuit corresponds to the energy $E^\ell(t)$ of $\delta x(t)$ in the linearized circuit. (That is, E^ℓ is the incremental energy computed assuming the linearized circuit.) In the nice coordinates, the energy in the linearized circuit when the thyristor is on is $|\delta x|^2$, the square of the Euclidean norm of the state. $|\delta y|^2$ is the energy in the linearized circuit when the thyristor is off.

Between switchings, the linearized circuit has no resistances, (3.6) and (3.7) describe lossless oscillations, and the energy $E^\ell(t)$ does not change.

At a switch off s_{off} , the change in energy

$$\begin{aligned} \Delta E^\ell(s_{\text{off}}) &= |\delta y(s_{\text{off}+})|^2 - |\delta x(s_{\text{off}-})|^2 \\ &= -|c\delta x(s_{\text{off}-})|^2 \end{aligned} \quad (3.10)$$

$$= -\frac{1}{2}L_r (\delta i(s_{\text{off}-}))^2 \quad (3.11)$$

since $|\delta y(s_{\text{off}+})|^2 = |P\delta x(s_{\text{off}-})|^2$ and

$$|\delta x|^2 = \delta x^t \delta x = \delta x^t (QP + c^t c) \delta x = |P\delta x|^2 + |c\delta x|^2.$$

The final step follows from (3.1) and the result agrees with the leading order term of (2.8).

At a switch on s_{on} , the change in energy

$$\begin{aligned} \Delta E^\ell(s_{\text{on}}) &= |\delta x(s_{\text{on}+})|^2 - |\delta y(s_{\text{on}-})|^2 \\ &= |\dot{c}x(s_{\text{on}+})\delta s_{\text{on}}|^2 \end{aligned} \quad (3.12)$$

$$= \frac{1}{2}L_r \left(\frac{di}{dt}(s_{\text{on}+})\right)^2 \delta s_{\text{on}}^2$$

since (3.9), $Q^t c^t = 0$, $cQ = 0$, and $Q^t Q = I$ imply that

$$|\delta x(s_{\text{on}+})|^2 = |c^t \dot{c}x(s_{\text{on}+})\delta s_{\text{on}}|^2 + |\delta y(s_{\text{on}-})|^2.$$

The final step follows from differentiating (3.1) and the result agrees with the leading order term of (2.9).

4. Incremental energy in multi-TCR circuit

This section applies the incremental energy results to circuits with inductors, capacitors, sources as before but with several thyristor controlled reactors. The nominal periodic steady state has period T with $2m$ distinct switchings. m is the number of thyristor switch offs in one period (m is also the number of thyristor switch ons in one period). Choose time 0 to occur in a switching state with minimum dimension p . Let $z(0) \in R^p$ denote the state at $t = 0$. The system equations take account of each thyristor switching encountered during the period by changing coordinates similarly to (3.2-3.5) [3,4].

An initial system perturbation $\delta z(0)$ at $t = 0$ with incremental energy $E(0) = |\delta z(0)|^2$ progresses through the period and arrives at the end of the period as the perturbation $\delta z(T)$ with incremental energy $E(T) = |\delta z(T)|^2$. Let ΔE_j^{on} and ΔE_j^{off} be given by (2.4) with the subscript j indicating that the expression is evaluated for the thyristor controlled reactor involved in the j^{th} switch on and the j^{th} switch off respectively. Since the incremental energy changes by ΔE_j^{off} or ΔE_j^{on} at each switch off or switch on,

$$E(T) = E(0) + \sum_{j=1}^m \Delta E_j^{\text{off}} + \sum_{j=1}^m \Delta E_j^{\text{on}} \quad (4.1)$$

We discuss the implications of (4.1) for the case when all the thyristor firing pulses are unperturbed ($s_2 = s_1$ for all switch ons). Then (2.4) implies that $\Delta E_j^{\text{on}} = 0$ and $\Delta E_j^{\text{off}} \leq 0$ for all j . Moreover, (4.1) implies that $|\delta z(T)|^2 \leq |\delta z(0)|^2$ for all $\delta z(0)$ so that the incremental energy can never increase. In particular, the nominal trajectory is stable. Moreover, the loss of a nonnegative amount of incremental energy at each switch off tends to damp the perturbation.

We now investigate the energy $E^\ell(t)$ in the linearized circuit (recall that $E^\ell(t)$ is the incremental energy to leading order for a small perturbation). Then $\Delta E_j^{\text{off}} =$

$-\left(\frac{1}{2}L_r \delta i(s_{\text{off}-})\right)_j = -|a_j \delta z(0)|^2$ for some a_j and $\Delta E_j^{\text{on}} = \left(\frac{1}{2}L_r \delta i(s_{\text{on}+})\right)_j = |b_j \delta z(0)|^2$ for some b_j . Equation (4.1) becomes

$$E^\ell(T) = |\delta z(0)|^2 - \sum_{j=1}^m |a_j \delta z(0)|^2 + \sum_{j=1}^m |b_j \delta z(0)|^2 \quad (4.2)$$

When the thyristor firing pulses are perturbed, δs_{on} is generally nonzero. The space $A = \langle a_1, \dots, a_m \rangle$ is typically different from the space $B = \langle b_1, \dots, b_m \rangle$. Consider a perturbation δz such that $\delta z(0) \perp A$ and $\delta z(0) \notin B$. Then the summation in (4.2) involving a_i is zero and the summation involving b_i is strictly positive so that the incremental energy of the perturbation *strictly increases* after one period. Similarly, if $\delta z(0) \perp B$ and $\delta z(0) \notin A$, the incremental energy of the perturbation *strictly decreases* after one period. The space $C = \langle a_1, \dots, a_m, b_1, \dots, b_m \rangle$ has dimension at most $2m$, which is typically less than p . If $\delta z(0) \perp C$, the incremental energy of the perturbation is *unchanged* after one period. Thus we generally expect to be able to find perturbations such that $E^\ell(t)$ increases, decreases or is unchanged in one period.

We now relate incremental energy to the Poincaré map Jacobian used for stability analysis of the periodic steady state [11,2,6,8,7,3,4]. The Poincaré map F advances the state by one period T . If the nominal steady state periodic orbit passes through z_0 at time 0, z_0 is a fixed point of F and $F(z_0) = z_0$. If the system is not at a switching time bifurcation [3,13], the Poincaré map is differentiable and we write J for the Jacobian of the Poincaré map evaluated at z_0 . J is the linear map that advances a perturbation of system states by one period T through the linearized system, i.e., $\delta z(T) = J\delta z(0)$. Hence $E^\ell(T) = |J\delta z(0)|^2$. The steady state is exponentially stable if all the eigenvalues of J lie strictly within the unit circle. The incremental energy results can be rephrased in terms of the singular values of J . The singular values of J are the extreme values of (4.2) with $|\delta z(0)| = 1$. We argued above that when the thyristor firings are perturbed, J typically has singular values greater than, less than or equal to one.

5. Comments on dynamic models

Thyristor controlled reactors are often represented by controllable impedances in steady state analyses at fundamental frequency. However, since the thyristor controlled reactor is nonlinear, its small signal dynamics are not directly related to its static behavior. For example [7], consider a thyristor controlled reactor in series with a sinusoidal voltage source. The firing angle is constant and the steady state conduction time $s_{\text{off}} - s_{\text{on}}$ is greater than 0 and less than $T/2$. A steady state model can represent one or more harmonics of the periodic steady state. However, the Poincaré map Jacobian is always zero and the circuit damps all small perturbations of the state to zero.

We illustrate with two examples some problems with using an impedance model for a thyristor controlled reactor for dynamic analyses. For simplicity, we assume unperturbed thyristor firing pulses ($\delta s_{\text{on}} = 0$).

Example 1: The single phase Kayenta flexible AC transmission circuit [8] is a system with a thyristor controlled reactor and is used for power flow control. At a typical operating point ($s_{\text{off}} - s_{\text{on}} = T/12$) and neglecting circuit resistances, $J = \begin{pmatrix} 0.4791 & 0.6062 & -0.1690 \\ -0.7385 & 0.0876 & 0.0166 \\ -0.4613 & 0.4431 & 0.0121 \end{pmatrix}$ has eigenvalues at $0.1312, 0.2238 \pm j0.5498$ that lie well within the unit circle and hence the system is asymptotically stable. Moreover, there is an initial perturbation direction $\delta z(0) = (0.9914 \ 0.0734 \ -0.1081)^t$ for which the incremental energy of a small perturbation is unchanged after one period (see also Section 4). However, replacing the thyristor controlled reactor by a combination of resistors, capacitors and inductors yields a linear circuit which cannot both be asymptotically stable and preserve the incremental energy of the stated initial perturbation. (A circuit with resistors which is asymptotically stable must dissipate energy of all perturbations.)

Example 2: For systems operating at halfwave symmetric periodic orbits, the Jacobian H of the halfwave Poincaré map is used to check for fundamental resonance [2]. The single phase static VAR control circuit of [2] has $H = \begin{pmatrix} -0.9395 & -0.0126 \\ -0.2811 & -0.8540 \end{pmatrix}$ with eigenvalues at -0.97 and -0.8236 for $s_{\text{off}} - s_{\text{on}} = T/8$. Since H has negative simple eigenvalues, there is no real matrix A_{avg} such that $H = e^{A_{\text{avg}}T/2}$ [5]. That is, the eigenvalue behavior of H cannot be captured by representing the thyristor controlled reactor with a linear model. The negative eigenvalues persist over a region $0.105T \leq s_{\text{off}} - s_{\text{on}} \leq 0.155T$ (fundamental resonance occurs at $s_{\text{off}} - s_{\text{on}} = 0.140T$ [2]).

6. Conclusions

We consider a small perturbation to a nominal steady state trajectory of a circuit with thyristor controlled reactors, inductors, capacitors and time dependent, periodic sources. Misfire [13] and switching time bifurcation [6,13,4] effects are assumed not to occur. If the thyristor firing is unperturbed, there is no change of incremental energy at each thyristor switch on and a decrease in incremental energy at each thyristor switch off. Thus the thyristor switch offs damp the perturbation and the circuit is stable. If a thyristor firing is perturbed from the nominal case, then there is also an increase in incremental energy at the thyristor turn on. This could lead to growing perturbations and circuit instability, but need not necessarily do so for two reasons. First, a subsequent switch off could offset the increase in incremental energy. Second, an overall increase in incremental energy in one period does not necessarily imply instability. Similar results may be obtained for circuits with ideal diodes [4], except that since diodes have a negative voltage becoming zero at turn on, incremental energy decreases at turn on and its leading order term is zero.

We have derived simple formulas for the leading order changes in incremental energy at switchings and also derived the same formulas from the system linearized about the nominal steady state. We give a few examples which

suggest that the small signal dynamic behavior of circuits with thyristor controlled reactors is not captured by modeling the thyristor controlled reactor as an impedance.

The authors gratefully acknowledge funding in part from EPRI under contract RP 8050-03 and from NSF PYI grant ECS-9157192.

References

- [1] N.Christl, R.Hedin, et al., Advanced series compensation (ASC) with thyristor controlled impedance, *Cigré* 14/37/38-05, Aug.1992.
- [2] I.Dobson, S.G.Jalali, R.Rajaraman, Damping and resonance in a high power switching circuit, *Systems and Control Theory for Power Systems* (eds. J.H. Chow et al.), IMA vol. 64 in mathematics and its applications, Springer Verlag, pp. 137-156, 1995.
- [3] I. Dobson, S.G. Jalali, Surprising simplification of the Jacobian of a diode switching circuit, *IEEE Intl. Symp. on Circuits and Systems*, Chicago, IL, May 1993, pp. 2652-2655.
- [4] I.Dobson, Stability of ideal thyristor and diode switching circuits, submitted to *IEEE Trans. Circuits & Systems*, Part 1.
- [5] R.A. Horn, C.R. Johnson, *Topics in matrix analysis*, Cambridge University Press, Cambridge, 1989.
- [6] S.G.Jalali, I.Dobson, R.H.Lasseter, Instabilities due to bifurcation of switching times in a thyristor controlled reactor, *Power Electronics Specialists Conf.*, Toledo, Spain, July 1992, pp.546-552.
- [7] S.G.Jalali, *Harmonics and instabilities in thyristor based switching circuits*, PhD thesis, Univ. of Wisconsin-Madison, 1993.
- [8] S.G. Jalali, R.H. Lasseter, I. Dobson, Dynamic response of a thyristor controlled switched capacitor, *IEEE Trans. on Power Delivery*, vol. 9, no. 3, July 1994, pp.1609-1615.
- [9] E.S.Kuh, R.A.Rohrer, The state-variable approach to network analysis, *Proceedings IEEE*, vol.53, no.7, July 1965, pp.672-686.
- [10] E. Larsen, C. Bowler, et al., Benefits of thyristor controlled series compensation, *Cigré* 14/37/38-04, Paris 1992.
- [11] J.P. Louis, Non-linear and linearized models for control systems including static convertors, *Third Intl. Federation on Automatic Control, Symp. on Control in power electronics and electrical drives*, Lausanne, Switzerland, Sept. 1983 pp. 9-16.
- [12] T.J.E. Miller (ed.), *Reactive power control in electric systems*, Wiley, NY, 1982.
- [13] R. Rajaraman, I. Dobson, S.G. Jalali, Nonlinear dynamics and switching time bifurcations of a thyristor controlled reactor, *IEEE ISCAS*, Chicago, IL, May 1993, pp. 2180-2183.
- [14] S.R.Sanders, G.C.Vergheze, Lyapunov-based control for switched power converters, *IEEE Trans. on Power Electronics*, vol. 7, no. 1, Jan. 1992, pp. 17-24.

Appendix

We sketch a special case of the construction of the nice coordinates from [4] by adapting standard methods [9]. We assert that a normal tree for the circuit can be chosen so that the thyristor is a tree branch and the reactor is a link [4]. The state vector \tilde{x} consists of inductor link currents and capacitor branch voltages. In particular, the first component of \tilde{x} is the reactor current i so that $i = c\tilde{x}$. The circuit differential equations when the thyristor is on are $M\dot{\tilde{x}} = \tilde{A}\tilde{x} + \tilde{B}u$ where $M = \text{diag}\{\tilde{L}, \tilde{C}\}$, and \tilde{L} and \tilde{C} are inductance and capacitance matrices, and \tilde{A} describes a multiport associated with the circuit. We assume that $\tilde{L} > 0$ and $\tilde{C} > 0$. The differential equations when the thyristor is off and modeled as a voltage source $v(t)$ are $M\dot{\tilde{x}} = \tilde{A}\tilde{x} + \tilde{B}u + \alpha c^t v(t)$ for some constant α . That is, the thyristor voltage only contributes to the first differential equation. Now change coordinates with $x = M^{\frac{1}{2}}\tilde{x}/\sqrt{2}$ and let $A = M^{-\frac{1}{2}}\tilde{A}M^{-\frac{1}{2}}$, $B = M^{-\frac{1}{2}}\tilde{B}/\sqrt{2}$. Then $M\dot{\tilde{x}} = \tilde{A}\tilde{x} + \tilde{B}u$ becomes (3.2) and, noting that $M^{-\frac{1}{2}}c^t = L^{-\frac{1}{2}}c^t$, the off differential equations become $\dot{x} = Ax + Bu + \alpha L^{-\frac{1}{2}}c^T v_d$ and multiplication by P yields (3.3). Moreover, $i = c\tilde{x} = \sqrt{2}cM^{-\frac{1}{2}}x$ yields (3.1) and $|x|^2 = x^T x = \frac{1}{2}\tilde{x}^T M\tilde{x}$ is the circuit energy.